



产品规格书

Product Specification Sheet

TOP-CFP-100G-LR4

100G-BASE-LR4 10km CFP Optical Transceiver



Email: asale@topsf.com





Features

- Hot Pluggable CFP MSA package
- IEEE 802.3ba 100GBASE-LR4 compliant
- ITU-T 411-9D1F compliant
- CFP-MSA-HW-Spec-rev1-40 compliant
- Up to 10km for G.652 SMF
- Receiver: 4-lane x 25Gb/s PIN ROSAs
- Transmitter: 4-lane x 25Gb/s LAN-WDM EA-DFB TOSAs (1295.56,1300.05,1304.58,1309.14nm)
- 10x10G Electrical Serial Interface (CAUI/OTL4.10)
- MDIO management interface with Digital Diagnostic
- +3.3V power supply
- Power consumption less than 12W
- Compact size: 144.75 x 82 x 13.6 mm
- Operating case temperature: 0 to +70 °C
- Duplex SC or LC Receptacle
- ROHS-6 compliant

Applications

- 100GBase-LR4 Ethernet
- ITU-T OTU4

Description

- Topstar 's TOP-CFP-100G-LR4 CFP transceivers are designed for use in 100 Gigabit Ethernet links over 10km single module fiber, and it compliant to the CFP MSA and IEEE 802.3ba 100GBASE-LR4. Digital diagnostics are available via MDIO as specified in the CFP MSA Management Interface Specification.
- The transceiver's designs are optimized for high performance and cost efficiency to provide customers the best solutions for Datacom and Telecom applications.
- The transceiver is RoHS-6 compliant and lead-free per Directive 2002/95/EC.

**Product Selection****100Gb/s CFP electrical parameters****Absolute Maximum Ratings**

The limit of the maximum value is shown as below Table 1. (If operating out the limit of the maximum value will cause permanent damage).

Table 1 100Gb/s CFP module limit the maximum value

Parameter	Symbol	Conditions	Min.	Max	Unit
Storage temperature (case)	T _{stg}	—	-40	+85	°C
Relative humidity	RH	0	—	85	%
Damage Threshold for Receiver	P _{max}	—	—	+10.0	dBm
Power Supply	V _{cc} 3.3V	—	-0.3	+3.6	V
	V _{cc} 5.0V	—	—	—	V
Input 3.3V LVCMOS signal level	V _i	—	-0.3	V _{cc} +0.3	V
Input 1.2V LVCMOS signal level	V _i	—	-0.3	1.6	V
ESD Sensitivity on module and all host pins	HBM	Human Body model R=1.5K, C=100pF	—	2000	V

Recommended operating conditions

The recommended working conditions are shown as below Table 2.

Table 2 100Gb/s CFP recommended working conditions

Parameter	Symbol	Min.	Typ.	Max.	Unit
Operating Case Temperature	T _c	0	—	+70	°C
Supply voltage	V _{cc} 3.3V	+3.14	+3.3	+3.47	V
Supply Current	I _{cc} 3.3V	—	—	3.3	A
Power dissipation	P	—	—	12	W
Low Power dissipation	P _{Low}	—	—	2	W
In-rush Current	I _{-inrush}	—	—	50	mA/us
Turn-off rush Current	I _{-turnoff}	-50	—	—	mA/us
Link Distance	L	2M	—	10km	G.652 SMF



100Gb/s CFP Specifications

Optical Specifications

Table 3 100Gb/s CFP Optical Specifications (100GBase-LR4)

Parameter	Symbol	Condition	Min.	Typ.	Max.	Unit
Transmitter						
Channel data rate				25.7812		Gbps
Aggregate data rate				103.125		Gbps
Data rate variation			-100		+100	ppm
Lane Center Wavelength	λ_{CT0}		1294.53	1295.56	1296.59	nm
	λ_{CT1}		1299.02	1300.05	1301.09	nm
	λ_{CT2}		1303.54	1304.58	1305.63	nm
	λ_{CT3}		1308.09	1309.14	1310.19	nm
Total Average Launch Power	P _{out}		—	—	10.5	dBm
Average Launch Power per Lane	P _{each}		-4.3	—	4.5	dBm
Optical Modulation Amplitude per	OMA		-1.3	—	4.5	dBm
Difference in Launch power			—	—	5.0	dB
Launch power in OMA minus	P _{omatdp}		-2.3	—	—	dBm
Average Launch Power of	P _{off}	TX DIS=H	—	—	-30	dBm
Extinction Ratio	E _R		4	5.5	—	dB
SMSR	SMSR		30	—	—	dB
Dispersion Penalty	DP	10km SMF	—	—	2.2	dB
Relative Intensity Noise	RIN	Mod off	—	—	-130	dB/Hz
Optical Return Loss Tolerance	T _{RL}		—	—	20	dB
Transmitter reflectance	T _{ef}		—	—	-12	dB
Optical Eye Mask {X1, X2, X3,	EM		{0.25, 0.4, 0.45, 0.25, 0.28,			
Receiver						
Channel data rate				25.7812		Gbps
Data rate variation			-100		+100	ppm
Lane Center Wavelength	λ_{CT0}		1294.53	1295.56	1296.59	nm
	λ_{CT1}		1299.02	1300.05	1301.09	nm
	λ_{CT2}		1303.54	1304.58	1305.63	nm
	λ_{CT3}		1308.09	1309.14	1310.19	nm
Damage threshold	P _{DT}		—	5.5	—	dBm
Average receiver power per lane	R _{pow}		-10.6	—	4.5	dBm



Receive power OMA per Lane	Rovl		—	—	4.5	dBm
Difference in receive power			—	—	5.5	dB
Receiver Sensitivity(OMA) per	Psen		—	—	-8.6	dBm
Stressed Receiver Sensitivity per	Psen_str		—	—	-6.8	dBm
Receiver Reflectance	Ref		—	—	-26	dB
Conditions of stressed receiver sensitivity test						

Vertical eye closure penalty per Lane			—	—	1.8	dB
Stressed eye jitter per Lane			—	—	0.3	UI
Rx-Lane LOS Assert			—	-18	—	dBm
Rx-Lane LOS Deassert			—	-15	—	dBm
Rx-Lane LOS Hysteresis			0.5	—	—	dB

Note1. Please refer to Figure 1

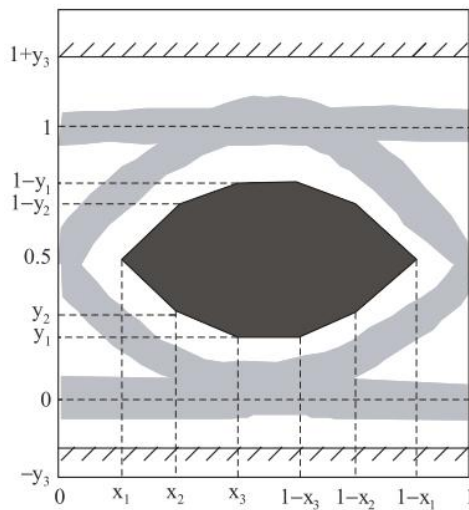

Figure 1. Transmission eye mask definition

Table 4 100Gb/s CFP Optical Specifications (OTU4)

Parameter	Symbol	Condition	Min.	Typ.	Max.	Unit
Transmitter						
Channel data rate				27.9525		Gbps
Aggregate data rate				111.809		Gbps
Data rate variation			-20		+20	ppm
Lane Center Wavelength	λ_{CT0}		1294.53	1295.56	1296.59	nm
	λ_{CT1}		1299.02	1300.05	1301.09	nm
	λ_{CT2}		1303.54	1304.58	1305.63	nm
	λ_{CT3}		1308.09	1309.14	1310.19	nm
Total Average Launch Power	Pout		—	—	8.9	dBm



Average Launch Power per Lane	Peach		-2.5	—	2.9	dBm
Optical Modulation Amplitude per Lane	OMA		-1.2	—	4.5	dBm
Difference in Launch power between any two lanes(OMA)			—	—	5.0	dB
Average Launch Power of TX_DIS Transmitter per lane	Poff	TX_DIS=H	—	—	-30	dBm
Extinction Ratio	ER		7	—	—	dB

SMSR	SMSR		30			dB
Relative Intensity Noise	RIN	Mod off	—	—	-130	dB/Hz
Optical Return Loss Tolerance	T _{RL}		—	—	20	dB
Transmitter reflectance	T _{ef}		—	—	-12	dB
Optical Eye Mask {X1, X2, X3, Y1, Y2, Y3} ¹	EM		{0.25, 0.4, 0.45, 0.25, 0.28, 0.4}			

Receiver

Channel data rate				27.9525		Gbps
Data rate variation			-20		+20	ppm
Lane Center Wavelength	λ_{CR0}		1294.53	1295.56	1296.59	nm
	λ_{CR1}		1299.02	1300.05	1301.09	nm
	λ_{CR2}		1303.54	1304.58	1305.63	nm
	λ_{CR3}		1308.09	1309.14	1310.19	nm
Damage threshold	P _{DT}		—	5.5	—	dBm
Average receiver power per lane	R _{pow}		—	—	4.5	dBm
Receiver power OMA per lane	R _{ovl}		—	—	4.5	dBm
Difference in receive power between any two lanes(OMA)			—	—	5.5	dB
Optical path penalty					1.5	dB
Receiver Sensitivity per lane ²	P _{sen}		—	—	-10.3	dBm
Receiver Sensitivity(OMA) per lane ²	P _{sen_OMA}				-9.1	dBm



Receiver Reflectance	Ref		—	—	-26	dB
Rx-Lane LOS Assert			—	-18	—	dBm
Rx-Lane LOS Deassert			—	-15	—	dBm
Rx-Lane LOS Hysteresis			0.5	—	—	dB

Note1. Please refer to Figure 1

Note2. OTU-4 Rate, BER < 10⁻¹² with FEC, ER > 7dB

Electrical specifications

High Speed I/O interface

Table 5 100Gb/s CFP Electrical High Speed I/O Interface Specifications

Parameter	Symbol	Condition	Min.	Typ.	Max.	Unit
Transmitter (CAUI input interface)						
Signal Rate Per Lane				10.3125		Gb/s
Signal Rate Tolerance			-100		100	ppm
AC Common Mode input Voltage Tolerance(RMS)					20	mV
Differential input return loss	R _{diff}	IEEE 802.3ba-2010	See Equation (83B-7)			dB
Total Input Jitter Tolerance	T _{jin}				0.62	UI

Deterministic Input Jitter Tolerance	T _{din}				0.42	UI
Transmitter Input Eye Mask (X1, X2)				(0.31, 0.5)		UI ¹
Transmitter Input Eye Mask (Y1, Y2)				(42.5, 425)		mV ¹
Receiver (CAUI output interface)						
Signal Rate Per Lane				10.3125		Gb/s
Signal Rate Tolerance			-100		100	ppm
Single-ended output voltage	V _{osig}		-0.4		4	V
Output AC common-mode voltage(RMS)	V _{ocomAC}				15	mV
Output transition time	Tr	20%~80%	24	—	—	ps



Differential output return loss		IEEE 802.3ba-2010	See Equation (83B-5)		dB
Total Jitter	T_j			0.4	UI
Deterministic Jitter	T_{dj}			0.25	UI
Receiver Output Eye Mask (X1, X2)			(0.2, 0.5)		UI ²
Receiver Output Eye Mask (Y1, Y2)			(136, 380)		mV ²

Note1. refer to figure 2
 Note2. refer to figure 3

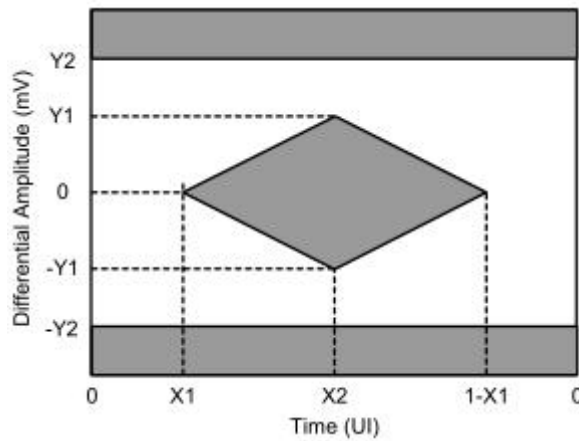

Figure 2. CAUI receiver eye mask

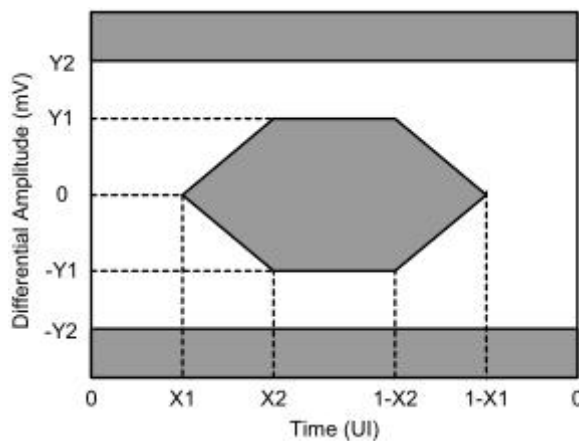

Figure 3. CAUI transmitter eye mask

Low Speed I/O interface

Table 6 100Gb/s CFP 3.3V LVCMOS Electrical Characteristics

Parameter	Symbol	Condition	Min.	Typ.	Max.	Unit
-----------	--------	-----------	------	------	------	------



Supply Voltage	V _{CC}		3.2	3.3	3.4	V
Input High Voltage	V _{IH}		2		V _{CC} +0.3	V
Input Low Voltage	V _{IL}		-0.3		0.8	V
Input Leakage Current	I _{IN}		-10		+10	mA
Output High Voltage (I _{OH} = -100uA)	V _{OH}		V _{CC} -0.2		V _{CC} +0.3	V
Output Low Voltage (I _{OL} = 100uA)	V _{OL}		-0.3		0.2	V
Minimum Pulse Width of Control Pin Signal	t _{CNTL}		100			us

Note. (MOD_RSTn, MOD_LOPWR, TX_DIS, PRG_CNTL, MOD_ABS, RX_LOS, GLB_ALRMn, PRG_ALRM) are LVCMOS I/O interfaces.

Table 7 100Gb/s CFP 1.2V LVCMOS Electrical Characteristics

Parameter	Symbol	Condition	Min.	Typ.	Max.	Unit
Input High Voltage	V _{IH}		0.84		1.5	V
Input Low Voltage	V _{IL}		-0.3		0.36	V
Input Leakage Current	I _{IN}		-100		+100	uA
Output High Voltage	V _{OH}		1.0		1.5	V
Output Low Voltage	V _{OL}		-0.3		0.2	V
Output High Current	I _{OH}				-4	mA
Output Low Current	I _{OL}		+4			mA
Input capacitance	C _i				10	pF

Note. (MDIO, MDC, PRTADR4:0) are 1.2V LVCMOS I/O interfaces

Table 8 100Gb/s CFP Timing Parameters for CFP Hardware Signal Pins

Parameter	Symbol	Condition	Min.	Typ.	Max.	Unit
Hardware MOD_LOPWR assert	t _{MOD_LOPWR_assert}				1	ms
Hardware MOD_LOPWR deassert	t _{MOD_LOPWR_deassert}				10	s
Receiver Loss of Signal Assert Time	t _{loss_assert}				100	us
Receiver Loss of Signal De-Assert Time	t _{loss_deassert}				100	us
Global Alarm Assert Delay Time	GLB_ALRMn_assert				150	ms
Global Alarm De-Assert Delay Time	GLB_ALRMn_deassert				150	ms
Management Interface Clock Period	t _{prd}			250		ns



Host MDIO t_setup	t_setup		10			ns
Host MDIO t_hold	t_hold		10			ns
CFP MDIO t_delay	t_delay		0		175	ns
Initialization time from Reset	t_initialize				2.5	s
Transmitter Disabled (TX_DIS asserted)	t_deassert				100	us
Transmitter Enabled (TX_DIS de-asserted)	t_assert				2	ms

Table 9 100Gb/s CFP MDIO and MDC Timing Characteristics

Parameter	Symbol	Condition	Min.	Typ.	Max.	Unit
Management Interface Clock Frequency	F_MDC		0.1		4	MHz
Management Interface Clock Period	t_prd		250		10000	ns
Host MDIO t_setup	t_setup		10			ns
Host MDIO t_hold	t_hold		10			ns
CFP MDIO t_delay ¹	t_delay		0		175	ns
MDC high and low time	twidth		40		60	%
			160			ns
MDIO/MDC termination in CFP	Zt		100			kOhm

Note1. Delay from MDC rising edge to MDIO data change

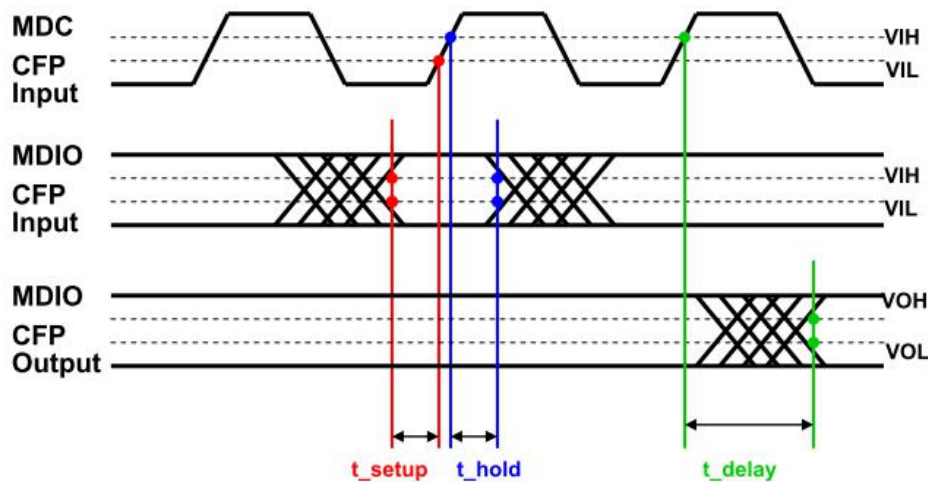

Figure 4. 100Gb/s CFP MDIO & MDC Timing Diagram

Clock interface

Table 10 100Gb/s CFP Reference Clock Characteristics



Parameter	Symbol	Condition	Min.	Typ.	Max.	Unit
Impedance	Zd		80	100	120	ohm
Frequency			1/64 of host lane rate			
Frequency Stability	Xf		-100		+100	ppm ¹
			-20		+20	ppm ²
Input Differential Voltage	Vdiff		400		1200	mV ³
RMS Jitter	σ				10	ps ⁴
Clock Duty Cycle			40		60	%
Clock Rise/Fall Time 10/90%	Tr/f		200		1250	ps ⁵

Note1. For Ethernet applications

Note2. For Telecom applications

Note3. Peak to Peak Differential

Note4. Random Jitter. Over frequency band of 10kHz < f < 10MHz Note5. 1/64 of electrical lane

Table 11 100Gb/s CFP Transmitter & Receiver Monitor Clock Characteristics

Parameter	Symbol	Condition	Min.	Typ.	Max.	Unit
Impedance	Zd		80	100	120	ohm
Frequency			1/8 of network lane rate			
Output Differential Voltage	Vdiff		400		1200	mV ¹
Clock Duty Cycle			40		60	%

Note1. Peak to Peak Differential

100Gb/s CFP Function Diagram

Internal reference structure

The internal structure of 100Gb/s CFP shown as Figure 5.

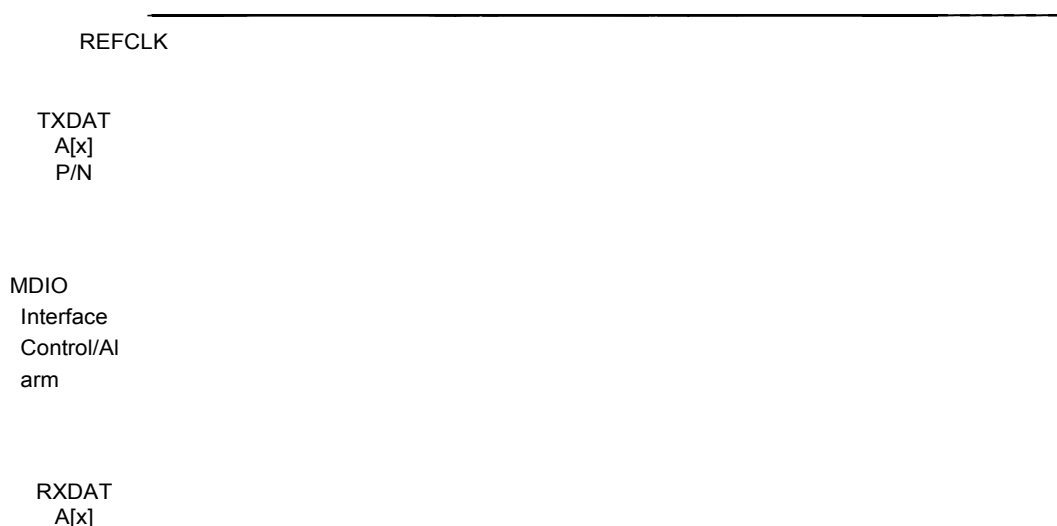

Figure 5. 10km 100Gb/s CFP internal structure

Recommended Interface Circuit

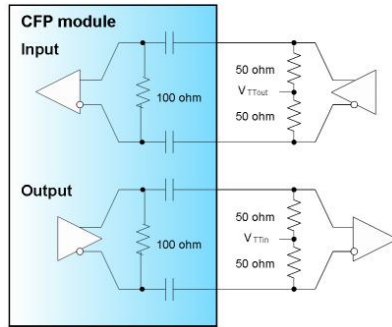

Figure 6. Recommended High Speed I/O for Data and Clocks

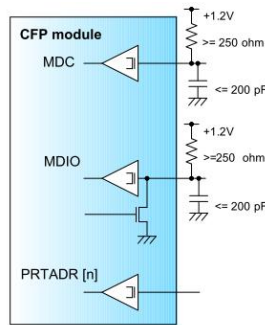

Figure 7. Recommended MDIO Interface Termination

Pin layout

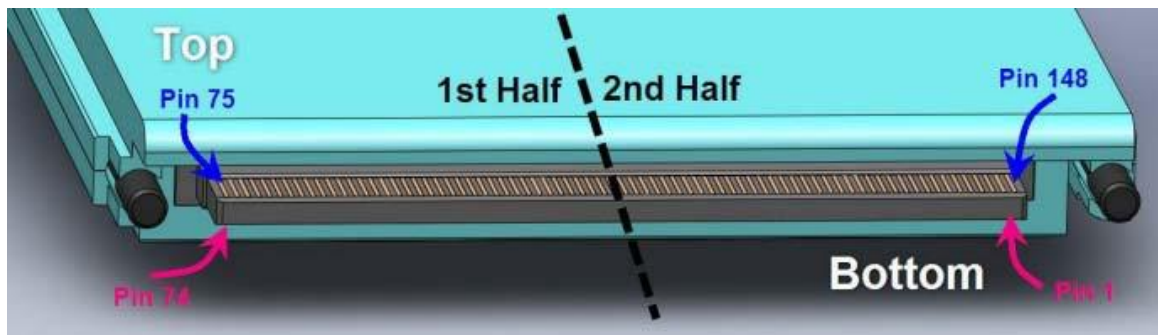

Figure 8. CFP Module Pad Layout



	Top Row (2nd Half)		Bottom Row (2nd Half)		Top Row (1st Half)		Bottom Row (1st Half)
148	GND	1	3.3V_GND	111	GND	38	MOD_ABS
147	REFCLKn	2	3.3V_GND	110	N.C.	39	MOD_RSTn
146	REFCLKp	3	3.3V_GND	109	N.C.	40	RX_LOS
145	GND	4	3.3V_GND	108	GND	41	GLB_ALRMn
144	N.C.	5	3.3V_GND	107	RX9n	42	PRTADR4
143	N.C.	6	3.3V	106	RX9p	43	PRTADR3
142	GND	7	3.3V	105	GND	44	PRTADR2
141	TX9n	8	3.3V	104	RX8n	45	PRTADR1
140	TX9p	9	3.3V	103	RX8p	46	PRTADR0
139	GND	10	3.3V	102	GND	47	MDIO
138	TX8n	11	3.3V	101	RX7n	48	MDC
137	TX8p	12	3.3V	100	RX7p	49	GND
136	GND	13	3.3V	99	GND	50	VND_IO_F
135	TX7n	14	3.3V	98	RX6n	51	VND_IO_G
134	TX7p	15	3.3V	97	RX6p	52	GND
133	GND	16	3.3V_GND	96	GND	53	VND_IO_H
132	TX6n	17	3.3V_GND	95	RX5n	54	VND_IO_J
131	TX6p	18	3.3V_GND	94	RX5p	55	3.3V_GND
130	GND	19	3.3V_GND	93	GND	56	3.3V_GND
129	TX5n	20	3.3V_GND	92	RX4n	57	3.3V_GND
128	TX5p	21	VND_IO_A	91	RX4p	58	3.3V_GND
127	GND	22	VND_IO_B	90	GND	59	3.3V_GND
126	TX4n	23	GND	89	RX3n	60	3.3V
125	TX4p	24	(TX_MCLKn)	88	RX3p	61	3.3V
124	GND	25	(TX_MCLKp)	87	GND	62	3.3V
123	TX3n	26	GND	86	RX2n	63	3.3V
122	TX3p	27	VND_IO_C	85	RX2p	64	3.3V
121	GND	28	VND_IO_D	84	GND	65	3.3V
120	TX2n	29	VND_IO_E	83	RX1n	66	3.3V
119	TX2p	30	PRG_CNTL1	82	RX1p	67	3.3V
118	GND	31	PRG_CNTL2	81	GND	68	3.3V
117	TX1n	32	PRG_CNTL3	80	RX0n	69	3.3V
116	TX1p	33	PRG_ALRM1	79	RX0p	70	3.3V_GND
115	GND	34	PRG_ALRM2	78	GND	71	3.3V_GND
114	TX0n	35	PRG_ALRM3	77	(RX_MCLKn)	72	3.3V_GND
113	TX0p	36	TX_DIS	76	(RX_MCLKp)	73	3.3V_GND
112	GND	37	MOD_LOPWR	75	GND	74	3.3V_GND

Figure 9. CFP Module Pin Map

Note1: Pin 21,22,27,28,29,50,51,53,54 are internally used and NOT allowed to connect any signal and power supply or GND

Note2: Pin 24,25,76,77 are disabled unless MCLK output is enabled via MDIO



Pin definition

Table 12 100Gb/s CFP Pin Definition(Bottom row)

PIN	Name	I/O	Logic	Description
1	3.3V_GND			3.3V Module Supply Voltage Return Ground, can be separate or tied together with Signal Ground
2	3.3V_GND			
3	3.3V_GND			
4	3.3V_GND			
5	3.3V_GND			
6	3.3V			3.3V Module Supply Voltage
7	3.3V			3.3V Module Supply Voltage
8	3.3V			3.3V Module Supply Voltage
9	3.3V			3.3V Module Supply Voltage
10	3.3V			3.3V Module Supply Voltage
11	3.3V			3.3V Module Supply Voltage
12	3.3V			3.3V Module Supply Voltage
13	3.3V			3.3V Module Supply Voltage
14	3.3V			3.3V Module Supply Voltage
15	3.3V			3.3V Module Supply Voltage
16	3.3V_GND			3.3V Module Supply Voltage Return Ground, can be separate or tied together with Signal Ground
17	3.3V_GND			
18	3.3V_GND			
19	3.3V_GND			
20	3.3V_GND			
21	VND_IO_A	I/O		Module Vendor I/O. Must No Connect at host board
22	VND_IO_B	I/O		Module Vendor I/O. Must No Connect at host board
23	GND			
24	TX_MCLKn	O	CML	TX Monitor Clock Output (Negative)
25	TX_MCLKp	O	CML	TX Monitor Clock Output (Positive)
26	GND			
27	VND_IO_C	I/O		Module Vendor I/O. Must No Connect at host board
28	VND_IO_D	I/O		Module Vendor I/O. Must No Connect at host board
29	VND_IO_E	I/O		Module Vendor I/O. Must No Connect at host board
30	PRG_CNTL1	I	LVC MOS w/ PUR	Programmable Control 1 set over MDIO, MSA Default: TRXIC_RSTn, TX & RX ICs reset, "0": reset, "1" or NC: enabled = not used 4.75kohm pull up in the module
31	PRG_CNTL2	I	LVC MOS w/ PUR	Programmable Control 2 set over MDIO, MSA Default: Hardware Interlock LSB, "00": ≤8W, "01": ≤16W, "10": ≤24W, "11" or NC: ≤32W = not used 4.75kohm pull up in the module



32	PRG_CNTL3	I	LVC MOS w/ PUR	Programmable Control 3 set over MDIO, MSA Default: Hardware Interlock MSB, "00": ≤8W, "01": ≤16W, "10": ≤24W, "11" or NC: ≤32W = not used 4.75kohm pull up in the module
33	PRG_ALARM1		LVC MOS	Programmable Alarm 1 set over MDIO, MSA Default:

		O		HIPWR_ON, "1": module power up completed, "0": module not high powered up
34	PRG_ALARM2	O	LVC MOS	Programmable Alarm 2 set over MDIO, MSA Default: MOD_READY, "1": Ready, "0": notReady.
35	PRG_ALARM3	O	LVC MOS	Programmable Alarm 3 set over MDIO, MSA Default: MOD_FAULT, fault detected, "1": Fault, "0": No Fault
36	TX_DIS	I	LVC MOS w/ PUR	Transmitter Disable for all lanes, "1" or NC = transmitter disabled, "0" = transmitter enabled
37	MOD_LOPWR	I	LVC MOS w/ PUR	Module Low Power Mode. "1" or NC: module in low power (safe) mode, "0": power-on enabled 4.75kohm pull up in the module
38	MOD_ABS	O	GND	Module Absent. "1" or NC: module absent, "0": module present, Pull Up Resistor on Host
39	MOD_RSTn	I	LVC MOS w/ PDR	Module Reset. "0" resets the module, "1" or NC = module enabled, 4.75kohm Pull Down Resistor in Module
40	RX_LOS	O	LVC MOS	Receiver Loss of Optical Signal, "1": low optical signal, "0": normal condition
41	GLB_ALRMn	O	LVC MOS	Global Alarm. "0": alarm condition in any MDIO Alarm register, "1": no alarm condition, Open Drain, Pull Up Resistor on Host
42	PRTADR4	I	1.2V CMOS	MDIO Physical Port address bit 4
43	PRTADR3	I	1.2V CMOS	MDIO Physical Port address bit 3
44	PRTADR2	I	1.2V CMOS	MDIO Physical Port address bit 2
45	PRTADR1	I	1.2V CMOS	MDIO Physical Port address bit 1
46	PRTADR0	I	1.2V CMOS	MDIO Physical Port address bit 0
47	MDIO	I/O	1.2V CMOS	Management Data I/O bi-directional data (electrical specs as per 802.3ae and ba)
48	MDC	I	1.2V CMOS	Management Data Clock (electrical specs as per 802.3ae and ba)
49	GND			
50	VND_IO_F	I/O		Module Vendor I/O. Must No Connect at host board



51	VND_IO_G	I/O		Module Vendor I/O. Must No Connect at hostboard
52	GND			
53	VND_IO_H	I/O		Module Vendor I/O. Must No Connect at hostboard
54	VND_IO_J	I/O		Module Vendor I/O. Must No Connect at hostboard
55	3.3V_GND			3.3V Module Supply Voltage Return Ground, can be
56	3.3V_GND			separate or tied together with Signal Ground

57	3.3V_GND			
58	3.3V_GND			
59	3.3V_GND			
60	3.3V			3.3V Module Supply Voltage
61	3.3V			3.3V Module Supply Voltage
62	3.3V			3.3V Module Supply Voltage
63	3.3V			3.3V Module Supply Voltage
64	3.3V			3.3V Module Supply Voltage
65	3.3V			3.3V Module Supply Voltage
66	3.3V			3.3V Module Supply Voltage
67	3.3V			3.3V Module Supply Voltage
68	3.3V			3.3V Module Supply Voltage
69	3.3V			3.3V Module Supply Voltage
70	3.3V_GND			3.3V Module Supply Voltage Return Ground, can be separate or tied together with Signal Ground
71	3.3V_GND			
72	3.3V_GND			
73	3.3V_GND			
74	3.3V_GND			

Table 13 100Gb/s CFP Pin Definition(Top raw)

PIN	Name	I/O	Logic	Description
75	GND			
76	RX_MCLKp	O		RX Monitor Clock Output (Positive)
77	RX_MCLKn	O		RX Monitor Clock Output (Negative)
78	GND			
79	RX0p	O	HS I/O	Lane 0 Receiver Output (Positive)
80	RX0n	O	HS I/O	Lane 0 Receiver Output (Negative)
81	GND			
82	RX1p	O	HS I/O	Lane 1 Receiver Output (Positive)
83	RX1n	O	HS I/O	Lane 1 Receiver Output (Negative)
84	GND			
85	RX2p	O	HS I/O	Lane 2 Receiver Output (Positive)
86	RX2n	O	HS I/O	Lane 2 Receiver Output (Negative)
87	GND			
88	RX3p	O	HS I/O	Lane 3 Receiver Output (Positive)
89	RX3n	O	HS I/O	Lane 3 Receiver Output (Negative)



90	GND			
91	RX4p	O	HS I/O	Lane 4 Receiver Output (Positive)
92	RX4n	O	HS I/O	Lane 4 Receiver Output (Negative)
93	GND			
94	RX5p	O	HS I/O	Lane 5 Receiver Output (Positive)
95	RX5n	O	HS I/O	Lane 5 Receiver Output (Negative)

96	GND			
97	RX6p	O	HS I/O	Lane 6 Receiver Output (Positive)
98	RX6n	O	HS I/O	Lane 6 Receiver Output (Negative)
99	GND			
100	RX7p	O	HS I/O	Lane 7 Receiver Output (Positive)
101	RX7n	O	HS I/O	Lane 7 Receiver Output (Negative)
102	GND			
103	RX8p	O	HS I/O	Lane 8 Receiver Output (Positive)
104	RX8n	O	HS I/O	Lane 8 Receiver Output (Negative)
105	GND			
106	RX9p	O	HS I/O	Lane 9 Receiver Output (Positive)
107	RX9n	O	HS I/O	Lane 9 Receiver Output (Negative)
108	GND			
109	NC			Not Connected Internally
110	NC			Not Connected Internally
111	GND			
112	GND			
113	TX0p	I	HS I/O	Lane 0 Transmitter Input (Positive)
114	TX0n	I	HS I/O	Lane 0 Transmitter Input (Negative)
115	GND			
116	TX1p	I	HS I/O	Lane 1 Transmitter Input (Positive)
117	TX1n	I	HS I/O	Lane 1 Transmitter Input (Negative)
118	GND			
119	TX2p	I	HS I/O	Lane 2 Transmitter Input (Positive)
120	TX2n	I	HS I/O	Lane 2 Transmitter Input (Negative)
121	GND			
122	TX3p	I	HS I/O	Lane 3 Transmitter Input (Positive)
123	TX3n	I	HS I/O	Lane 3 Transmitter Input (Negative)
124	GND			
125	TX4p	I	HS I/O	Lane 4 Transmitter Input (Positive)
126	TX4n	I	HS I/O	Lane 4 Transmitter Input (Negative)
127	GND			
128	TX5p	I	HS I/O	Lane 5 Transmitter Input (Positive)
129	TX5n	I	HS I/O	Lane 5 Transmitter Input (Negative)
130	GND			



131	TX6p	I	HS I/O	Lane 6 Transmitter Input (Positive)
132	TX6n	I	HS I/O	Lane 6 Transmitter Input (Negative)
133	GND			
134	TX7p	I	HS I/O	Lane 7 Transmitter Input (Positive)
135	TX7n	I	HS I/O	Lane 7 Transmitter Input (Negative)
136	GND			
137	TX8p	I	HS I/O	Lane 8 Transmitter Input (Positive)

138	TX8n	I	HS I/O	Lane 8 Transmitter Input (Negative)
139	GND			
140	TX9p	I	HS I/O	Lane 9 Transmitter Input (Positive)
141	TX9n	I	HS I/O	Lane 9 Transmitter Input (Negative)
142	GND			
143	NC			Not Connected Internally
144	NC			Not Connected Internally
145	GND			
146	REFCLKp	I		Reference Clock Input (Positive)
147	REFCLKn	I		Reference Clock Input (Negative)
148	GND			

100Gb/s CFP Mechanical Specifications

100Gb/s CFP mechanical dimensions should be compliant with CFP MSA specification. Detailed dimensions are shown in Figure 10.

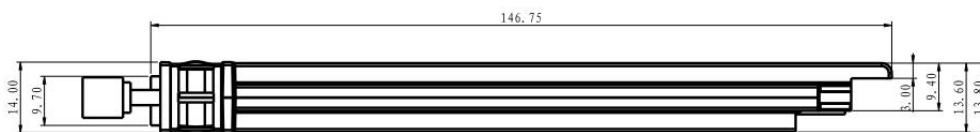

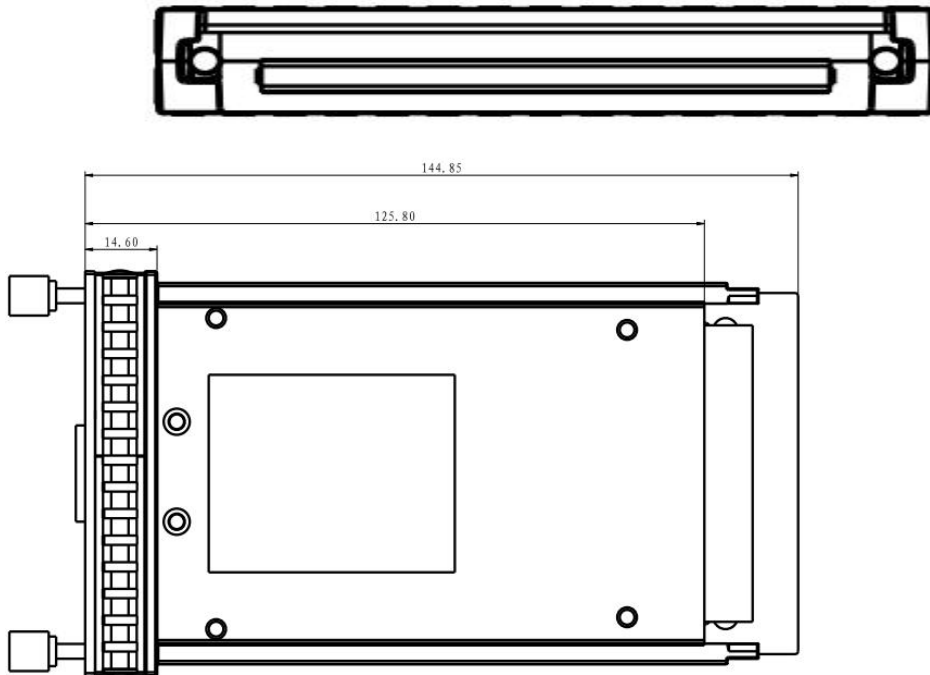

Figure 10. 100Gb/s CFP Mechanical Dimensions(unit:mm)

The mechanical dimensions of the electrical connectors on the CFP Host PCB are shown in Figure 11.



Figure 11 Mechanical Dimensions of Electrical Connectors on CFP Host PCB

Table 14 CFP Mechanical Characteristics

	Max.	Unit	Notes
Weight	350	g	
Flatness	0.15	mm	
Roughness	6.3	Ra	



Table 15/16 specify Host Connector Assembly Information for 100Gb/s CFP application.

Table 15 Host Connector Assembly Information (Tyco)

Part Number	Supplier	Part Name
2057626-1	Tyco Electronics	External Bracket Assembly
2057592-2	Tyco Electronics	Guide Rail
2057631-1	Tyco Electronics	Host Connector Cover Assembly
2057930-1	Tyco Electronics	Backer Plate Assembly
2057630-1	Tyco Electronics	Host Connector

Table 16 Host Connector Assembly Information (Yamaichi)

Part Number	Supplier	Part Name
CA009-1203-001	Yamaichi Electronics	External Bracket Assembly
CA009-1201-001	Yamaichi Electronics	Guide Rail
CA009-1400-001	Yamaichi Electronics	Host Connector Cover Assembly
CA009-1204-001	Yamaichi Electronics	Backer Plate Assembly
CA009-S001-001	Yamaichi Electronics	Host Connector

Management Interface

Topstar TOP-CFP-100G-LR4 CFP transceivers supports the MDIO interface specified in IEEE802.3 Clause 45. This 2-wire management data I/O interface is provided for the module status monitoring and control. The management data clock (MDC) provides clocking for the data that is passed on the MDIO port. Five further pins allow for loading of a port address (PORT_ADDR0-4) into the module.

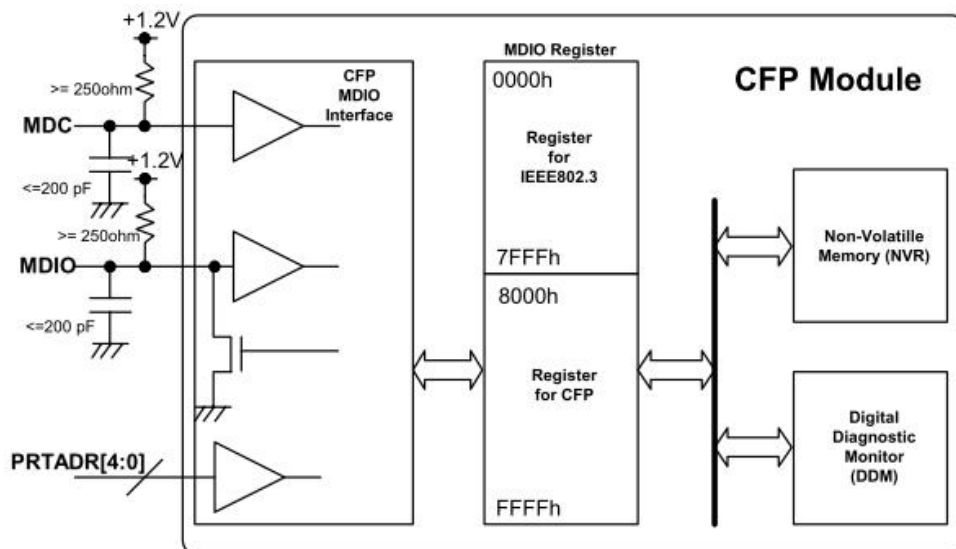

Figure 12 CFP MDIO Interface



Note: Capacitor represents stray capacity 600ohm pull-up is preferred
For more detailed information please refer to " CFP MSA Management Interface Specification Version 2.2 r06".

Ordering Information

Table 17 Order Information

Part No.	Application	Data Rate	Transmitter	Receiver	Fiber Type	Connector
TOP-CFP-100G-LR4-S	100GBase-LR4	103.125Gb/s	4*25G LAN-WDM TOSA	4*25G PIN ROSA	SMF	LC/PC
TOP-CFP-100G-LR4-D	100GBase-LR4 OTU4	103.125Gb/s 111.809Gb/s	4*25G LAN-WDM TOSA	4*25G PIN ROSA	SMF	LC/PC

Warnings

Handling Precautions: This device is susceptible to damage as a result of electrostatic discharge (ESD). A static free environment is highly recommended. Follow guidelines according to proper ESD procedures.

Laser Safety: Radiation emitted by laser devices can be dangerous to human eyes. Avoid eye exposure to direct or indirect radiation.



Topstar Technology Industrial Co., Ltd

**Add: F5, Rongcheng Building, 28 Yayuan Road Wuhe Community,
BanTian Street, Shenzhen, China**

Tel: +86 755 8255 2969 Email: lisa@topsfp.com

Skype: [lisalin6565](https://www.skype.com/people/lisalin6565)

Whatsapp: +86 13798265065

Wechat: 251081707

Facebook and Linked in: Topstar Technology Industrial Co., Ltd

