



TOP-QSFP-400G-LR8

TOP-QSFP-400G-LR8 NRZ 10km Optical Transceiver

Features:

- Compliant with IEEE 802.3bs standard:
 - 400GBASE-LR8 optical interface
 - 400GAUI-8 electrical interface
- Compliant with QSFP-DD MSA HW Rev 3.0 with duplex LC connector
- Case operating temperature 0°C to 70°C
- Two wire serial Interface with digital diagnostic monitoring
- Complies with EU Directive 2011/65/EU (RoHS compliant)
- Class 1 Laser

Module Characteristics

Table 1 – Absolute Maximum Ratings

Parameter	Symbol	Min.	Max.	Unit	Notes
Storage Temperature	T _s	-40	85	°C	
Supply Voltage	V _{CC}	-0.5	3.6	V	
Relative Humidity (non-condensing)	RH	5	95	%	
Data Input Voltage Differential	V _{DIP} -V _{DIN}	-	1	V	
Control Input Voltage	V _I	-0.3	V _{CC} +0.5	V	
Control Output Current	I _O	-20	20	mA	

Table 2 – Recommended Operating Conditions

Parameter	Symbol	Min.	Typical	Max.	Unit	Notes
Operating Case Temperature	T _{OPR}	0	-	70	°C	1
Power Supply Voltage	V _{CC}	3.135	3.3	3.465	V	
Instantaneous peak current at hot plug	I _{CC_IP}	-	-	TBD	mA	
Sustained peak current at hot plug	I _{CC_SP}	-	-	TBD	mA	
Maximum Power Dissipation	P _D	-	-	TBD	W	
Maximum Power Dissipation, Low Power Mode	P _{DLP}	-	-	TBD	W	
Signalling Speed per Lane	DRL	-	26.5625	-	Gbd	
Control Input Voltage High	V _{IH}	V _{CC} *0.7	-	V _{CC} +0.3	V	
Control Input Voltage Low	V _{IL}	-0.3	-	V _{CC} *0.3	V	
Two Wire Serial Interface Clock Rate	-	-	-	400	kHz	
Power Supply Noise	-	-	-	50	mVpp	
Rx Differential Data Output Load	-	-	100	-	Ohm	
Operating Distance	-	2	-	10000	m	



Functional Characteristics (Optical)

The following tables list the performance specifications for the various functional blocks of the integrated optical transceiver module.

Table 3 – Transmitter Optical Specifications

Parameter	Symbol	Min.	Typical	Max.	Unit	Notes
Wavelength L0	λ_{C0}	1272.55	1273.55	1274.54	nm	
Wavelength L1	λ_{C1}	1276.89	1277.89	1278.89	nm	
Wavelength L2	λ_{C2}	1281.25	1282.26	1283.27	nm	
Wavelength L3	λ_{C3}	1285.65	1286.67	1287.68	nm	
Wavelength L4	λ_{C4}	1294.53	1295.56	1296.59	nm	
Wavelength L5	λ_{C5}	1299.02	1300.06	1301.09	nm	
Wavelength L6	λ_{C6}	1303.54	1304.59	1305.63	nm	
Wavelength L7	λ_{C7}	1308.09	1309.14	1310.19	nm	
Side Mode Suppression Ratio	SMSR	30	-	-	dB	
Total Average Launch Power	AOP _T	-	-	13.2	dBm	
Average Launch Power, each lane	AOP _L	-2.8	-	5.3	dBm	1
Outer Optical Modulation Amplitude (OMA _{outer}), each Lane	T _{OMA}	0.2	-	5.7	dBm	
Difference in Launch Power between any two Lanes (OMA _{outer})	D _{T,OMA}	-	-	4	dB	
Launch Power in OMA _{outer} minus TDECQ, each lane for ER > 4.5dB	T _{OMA-TDECQ}	-1.2	-	-	dBm	
Launch Power in OMA _{outer} minus TDECQ, each lane for ER < 4.5dB	T _{OMA-TDECQ}	-1.1	-	-	dBm	
Transmitter and Dispersion Eye Closure for PAM4 (TDECQ), each lane	TDECQ	-	-	3.3	dB	
Average Launch Power of OFF Transmitter, each lane	T _{OFF}	-	-	-30	dBm	
Extinction Ratio	ER	3.5	-	-	dB	
RIN _{15,1} OMA	RIN	-	-	-132	dB/Hz	
Optical Return Loss Tolerance	ORL	-	-	15.1	dB	
Transmitter Reflectance	T _R	-	-	-26	dB	2

Note 1: Average launch power, each lane (min) is informative and not the principal indicator of signal strength

Note 2: Transmitter reflectance is defined looking into the transmitter

**Table 4 – Receiver Optical Specifications**

Parameter	Symbol	Min.	Typical	Max.	Unit	Notes
Wavelength L0	λ_{C0}	1272.55	1273.55	1274.54	nm	
Wavelength L1	λ_{C1}	1276.89	1277.89	1278.89	nm	
Wavelength L2	λ_{C2}	1281.25	1282.26	1283.27	nm	
Wavelength L3	λ_{C3}	1285.65	1286.67	1287.68	nm	
Wavelength L4	λ_{C4}	1294.53	1295.56	1296.59	nm	
Wavelength L5	λ_{C5}	1299.02	1300.06	1301.09	nm	
Wavelength L6	λ_{C6}	1303.54	1304.59	1305.63	nm	
Wavelength L7	λ_{C7}	1308.09	1309.14	1310.19	nm	
Damage Threshold, each Lane	AOP _D	6.3	-	-	dBm	
Average Receive Power, each Lane	AOP _R	-9.1	-	5.3	dBm	
Receive Power (OMAouter), each Lane	OMA _R	-	-	5.7	dBm	
Difference in Receive Power between any two Lanes (OMAouter)	D _{R_OMA}	-	-	4.5	dB	
Receiver Reflectance	RR	-	-	-26	dB	
Receiver Sensitivity (OMAouter), each Lane	S _{OMA}	-	-	-7.1	dBm	1
Stressed Receiver Sensitivity (OMAouter), each Lane	SRS	-	-	-4.7	dBm	2

Note 1: Receiver sensitivity (OMAouter), each lane (max) is informative and is defined for a transmitter with SECQ of 0.9 dB.

Note 2: Measured with conformance test signal at TP3 for the BER = 2.4×10^{-4}



Functional Characteristics (Electrical)

Table 5 – Electrical Specification High Speed Signal (compliant with IEEE 802.3bs 400GAUI-8)

Receiver (Module Output)						
Parameter	Symbol	Min.	Typical	Max.	Unit	Notes
AC common-mode output Voltage (RMS)		-	-	17.5	mV	
Differential output Voltage		-	-	900	mV	
Near-end Eye height, differential		70	-	-	UI	
Far-end Eye height, differential		30	-	-	UI	
Far end pre-cursor ratio		-	-	2.5	%	
Differential Termination Mismatch		-	-	10	%	
Transition Time (min, 20% to 80%)		9.5	-	-	ps	
DC common mode Voltage		-350	-	2850	mV	
Transmitter (Module Input)						
Parameter	Symbol	Min.	Typical	Max.	Unit	Notes
Differential pk-pk input Voltage tolerance		900	-	-	mV	
Differential termination mismatch		-	-	10	%	
Single-ended voltage tolerance range		-0.4	-	3.3	V	
DC common mode Voltage		-350	-	2850	mV	

Table 6 – Electrical Specification Low Speed Signal (compliant with QSFP-DD HW Rev 3.0)

Parameter	Symbol	Min.	Max.	Unit	Condition
Module output SCL and SDA	V_{OL}	0	0.4	V	
	V_{OH}	$V_{CC}-0.5$	$V_{CC}+0.3$	V	
Module Input SCL and SDA	V_{IL}	-0.3	$V_{CC}*0.3$	V	
	V_{IH}	$V_{CC}*0.7$	$V_{CC}+0.5$	V	
InitMode, ResetL and ModSelL	V_{IL}	-0.3	0.8	V	
	V_{IH}	2	$V_{CC}+0.3$	V	
IntL	V_{OL}	0	0.4	V	
	V_{OH}	$V_{CC}-0.5$	$V_{CC}+0.3$	V	



Pin Definitions

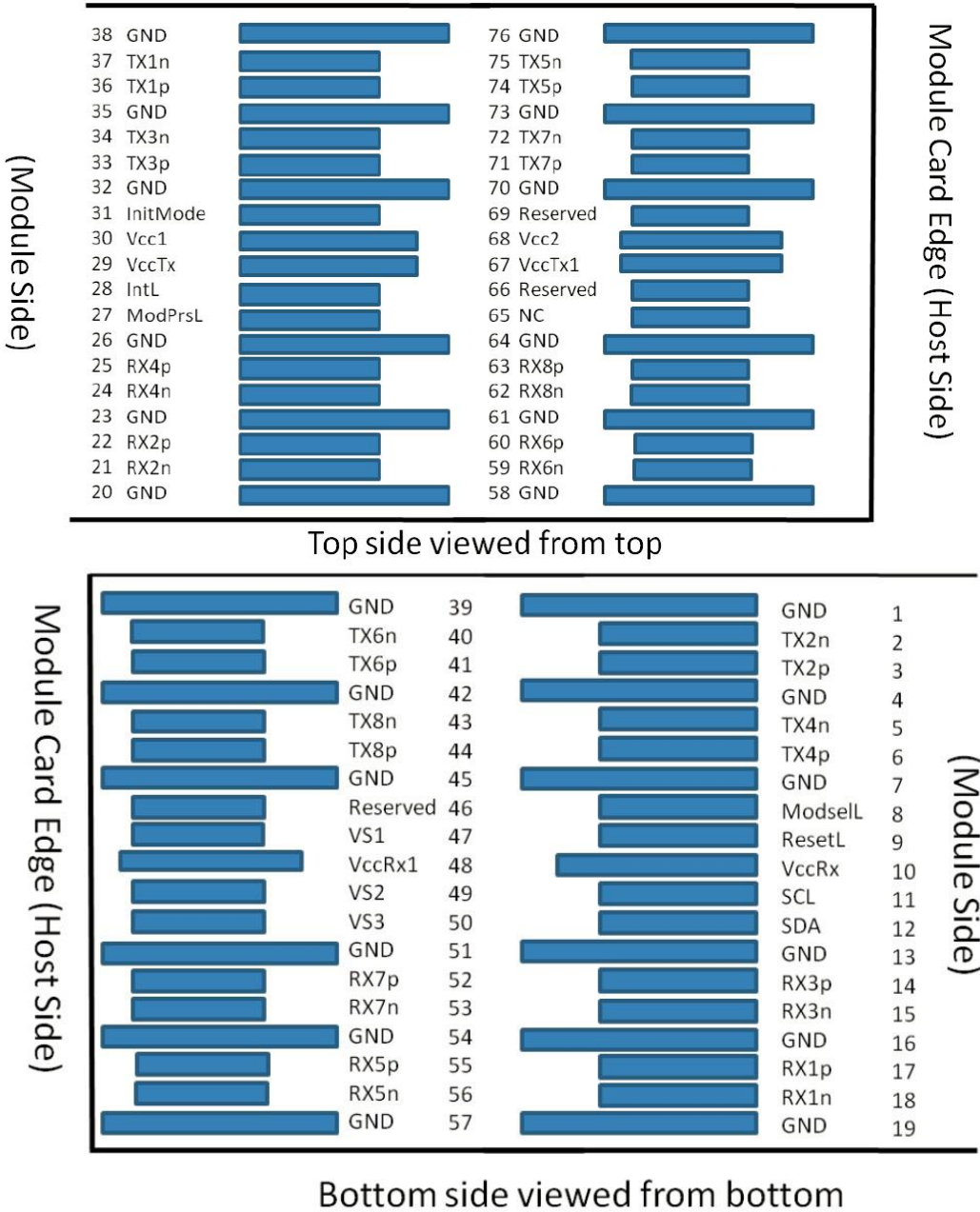

Figure 1 – Pin definitions of the module high speed inputs/outputs



Table 7 – Module Pin Definitions

Pin #	Logic	Symbol	Definition	Pin #	Logic	Symbol	Definition
1		GND	Ground	39		GND	Ground
2	CML-I	Tx2n	Transmitter Inverted Data Input	40	CML-I	Tx6n	Transmitter Inverted Data Input
3	CML-I	Tx2p	Transmitter Non-inverted Data Input	41	CML-I	Tx6p	Transmitter Non-inverted Data Input
4		GND	Ground	42		GND	Ground
5	CML-I	Tx4n	Transmitter Inverted Data Input	43	CML-I	Tx8n	Transmitter Inverted Data Input
6	CML-I	Tx4p	Transmitter Non-inverted Data Input	44	CML-I	Tx8p	Transmitter Non-inverted Data Input
7		GND	Ground	45		GND	Ground
8	LVTTTL-I	ModSelL	Module Select	46		Reserved	
9	LVTTTL-I	ResetL	Module Reset	47		VS1	Module Vendor Specific 1
10		VccRx	+3.3V Power Supply Receiver	48		VccRx1	3.3V Power Supply
11	LVC MOS -I/O	SCL	2-wire serial interface clock	49		VS2	Module Vendor Specific 2
12	LVC MOS -I/O	SDA	2-wire serial interface data	50		VS3	Module Vendor Specific 3
13		GND	Ground	51		GND	Ground
14	CML-O	Rx3p	Receiver Non-inverted Data Output	52	CML-O	Rx7p	Receiver Non-inverted Data Output
15	CML-O	Rx3n	Receiver Inverted Data Output	53	CML-O	Rx7n	Receiver Inverted Data Output
16		GND	Ground	54		GND	Ground
17	CML-O	Rx1p	Receiver Non-inverted Data Output	55	CML-O	Rx5p	Receiver Non-inverted Data Output
18	CML-O	Rx1n	Receiver Inverted Data Output	56	CML-O	Rx5n	Receiver Inverted Data Output
19		GND	Ground	57		GND	Ground
20		GND	Ground	58		GND	Ground
21	CML-O	Rx2n	Receiver Inverted Data Output	59	CML-O	Rx6n	Receiver Inverted Data Output
22	CML-O	Rx2p	Receiver Non-inverted Data Output	60	CML-O	Rx6p	Receiver Non-inverted Data Output
23		GND	Ground	61		GND	Ground
24	CML-O	Rx4n	Receiver Inverted Data Output	62	CML-O	Rx8n	Receiver Inverted Data Output
25	CML-O	Rx4p	Receiver Non-inverted Data Output	63	CML-O	Rx8p	Receiver Non-inverted Data Output
26		GND	Ground	64		GND	Ground
27	LVTTTL-O	ModPrsL	Module Present	65		NC	Not connected
28	LVTTTL-O	IntL	Interrupt	66		Reserved	
29		VccTx	+3.3V Power Supply Transmitter	67		VccTx1	3.3V Power Supply
30		Vcc1	+3.3V Power Supply	68		Vcc2	3.3V Power Supply
31	LVTTTL-I	InitMode	Initialization mode	69		Reserved	
32		GND	Ground	70		GND	Ground
33	CML-I	Tx3p	Transmitter Non-inverted Data Input	71	CML-I	Tx7p	Transmitter Non-inverted Data Input
34	CML-I	Tx3n	Transmitter Inverted Data Input	72	CML-I	Tx7n	Transmitter Inverted Data Input
35		GND	Ground	73		GND	Ground
36	CML-I	Tx1p	Transmitter Non-inverted Data Input	74	CML-I	Tx5p	Transmitter Non-inverted Data Input
37	CML-I	Tx1n	Transmitter Inverted Data Input	75	CML-I	Tx5n	Transmitter Inverted Data Input
38		GND	Ground	76		GND	Ground

Recommended QSFP-DD Host Board Schematic

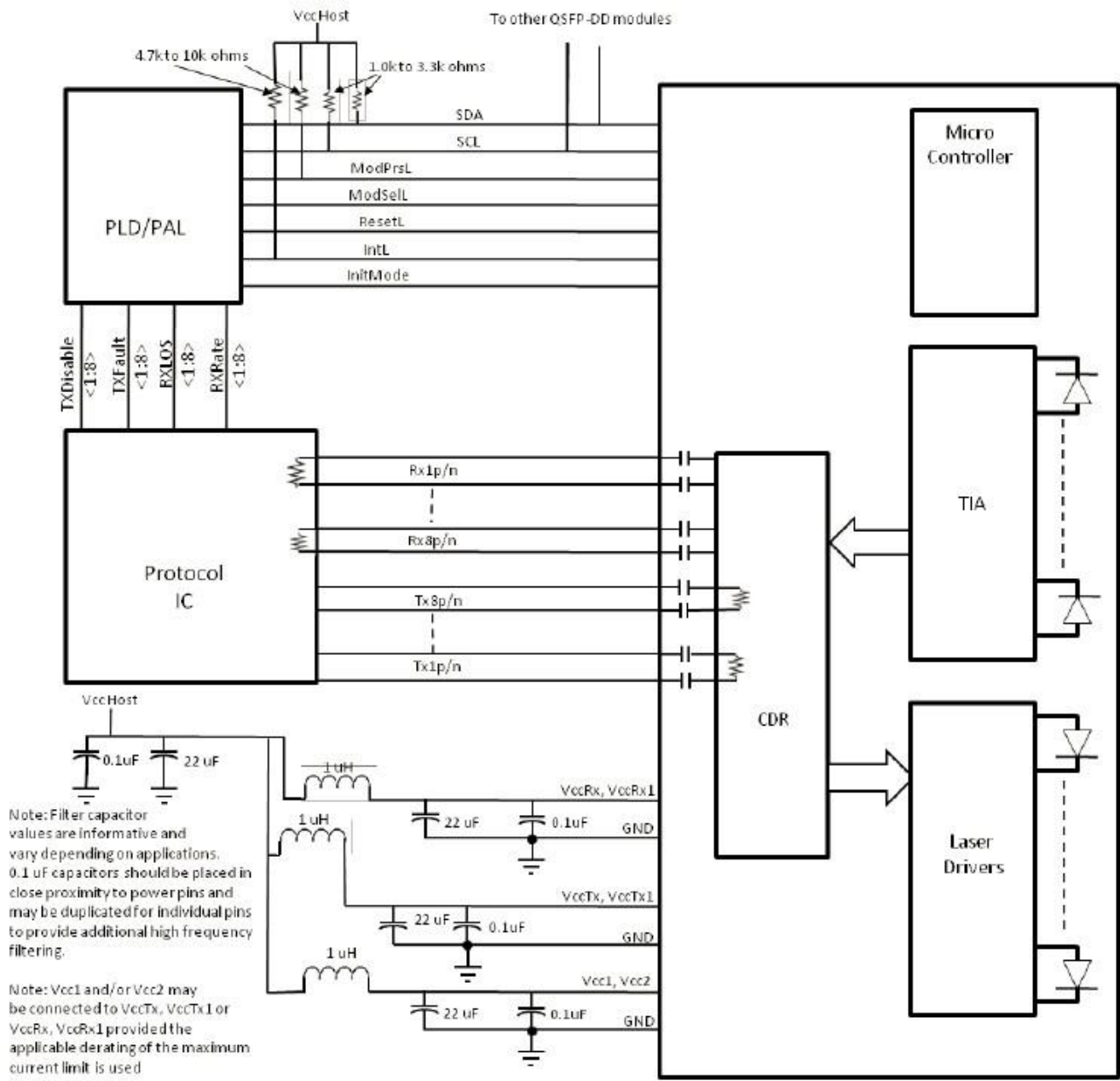

QSFP-DD Optical Module

Figure 2 – Recommended QSFP-DD Host Board Schematic



Table 8 – Timing for Soft Control and Status Functions

Parameter	Symbol	Min.	Max.	Unit	Notes
MgmtInit Duration		-	2000	ms	
ResetL Assert Time	t_reset_init	10	-	μs	
IntL Assert Time	ton_IntL	-	200	ms	
IntL Deassert Time	toff_IntL	-	500	ms	
Rx LOS Assert Time (fast mode)	ton_losf	-	1	ms	
Rx LOS Deassert (fast mode)	toff_losf	-	3	ms	
Tx Fault Assert Time	ton_Txfault	-	200	ms	
Flag Assert Time	ton_flag	-	200	ms	
Mask Assert Time	ton_mask	-	100	ms	
Mask Deassert Time	toff_mask	-	100	ms	
Module Select Wait Time	ModSelL Wait Time	-	N/A	ms	

Note 1: This feature is not supported

Table 9 – I/O Timing for Squelch and Disable

Parameter	Symbol	Min.	Max.	Unit	Notes
Rx Squelch Assert Time	ton_Rxsq	-	15	ms	
Rx Squelch Deassert Time	toff_Rxsq	-	1500	ms	
Tx Squelch Assert Time	ton_Txsq	-	400	ms	
Tx Squelch Deassert Time	toff_Txsq	-	1000	ms	
Tx Disable Assert Time (fast mode)	ton_Txdisf	-	3	ms	
Tx Disable Deassert Time (fast mode)	toff_Txdisf	-	10	ms	
Rx Output Disable Assert Time	ton_Rxdis	-	100	ms	
Rx Output Disable Deassert Time	toff_Rxdis	-	100	ms	
Squelch Disable Assert Time	ton_sqdis	-	100	ms	
Squelch Disable Deassert Time	toff_sqdis	-	100	ms	

Table 10 – Digital Diagnostics

Parameter	Range	Accuracy	Unit	Calibration
Temperature	0 to 70	±3	°C	Internal
Voltage	0 to V _{cc}	0.1	V	Internal
Tx Bias Current (Each Lane)	0 to 100	10%	mA	Internal
Tx Output Power (Each Lane)	-3.5 to +5.3	±3	dBm	Internal
Rx Receive Power (Each Lane)	-9.1 to +5.3	±3	dBm	Internal



Mechanical Diagram

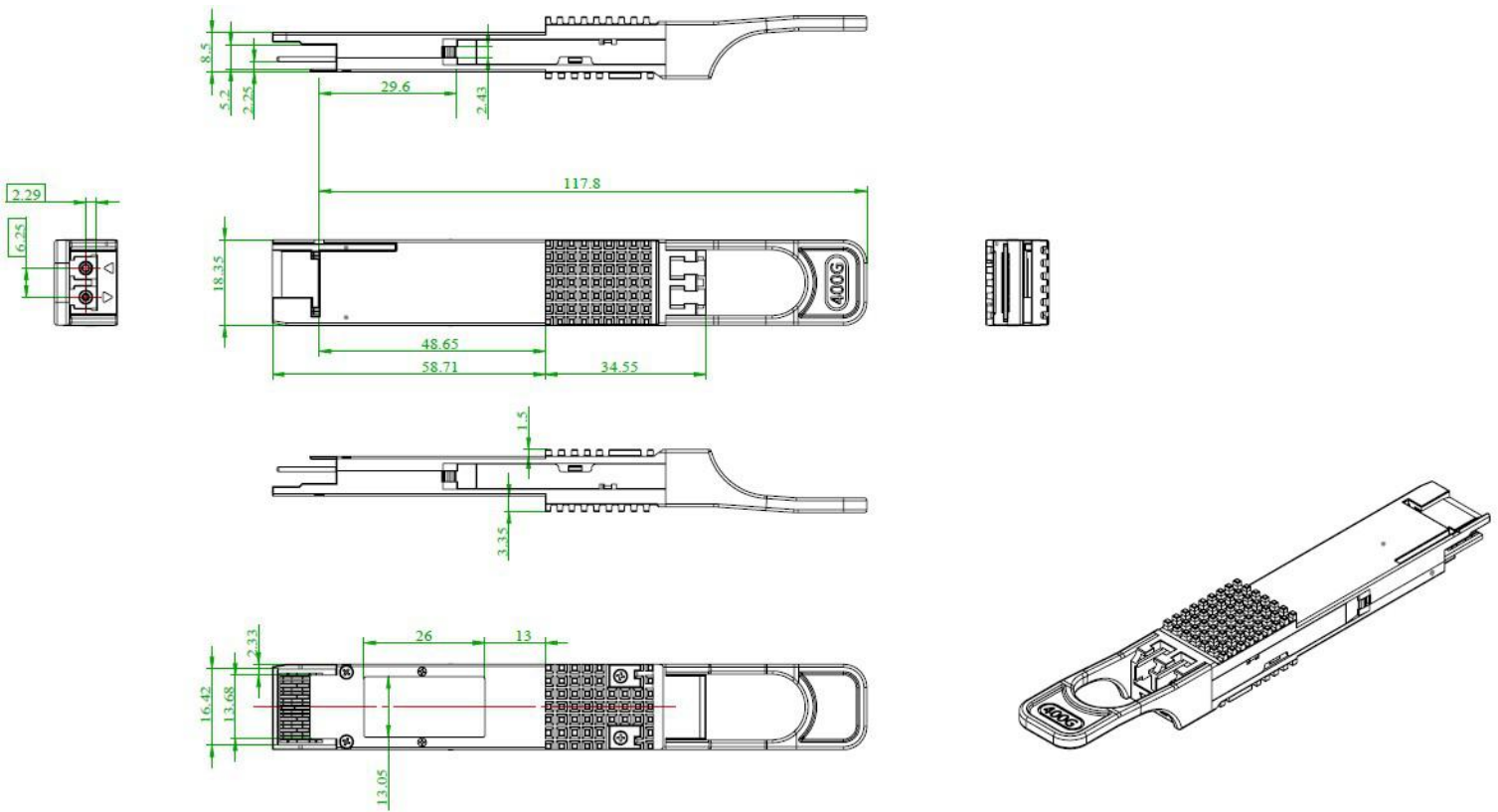

Ordering Information

Table 12 - Ordering Information

Part No.	Application	Data Rate	Laser TOPSTAR	Fiber Type
TOP-QSFP-400G-LR8	400GBASE-LR8	400GB Ethernet	EML	Single Mode Fiber

Table 13 - Device Handling/ESD Protection

1	
2	
3	
4	
5	
6	



Warnings

Handling Precautions: This device is susceptible to damage as a result of electrostatic discharge (ESD). A static free environment is highly recommended. Follow guidelines according to proper ESD procedures.

Laser Safety: Radiation emitted by laser devices can be dangerous to human eyes. Avoid eye exposure to direct or indirect radiation.

Topstar Technology Industrial Co., Ltd

Add: F5, Rongcheng Building, 28 Yayuan Road Wuhe Community, BanTian Street, Shenzhen, China

Tel: +86 755 8255 2969 Email: lisa@topsfp.com

Skype: [lisalin6565](https://www.skype.com/people/lisalin6565) Whatsapp: +86 13798265065

Wechat: 251081707

Facebook and Linked in: [Topstar Technology Industrial Co., Ltd](#)

